

## FISA TEHNICA

# Adaptor flansa PE100 SDR11 scurt injectat sudura cap cap

**Categorie:** Fitinguri injectate sudura cap-cap Fitinguri SDR11 injectate sudura cap cap

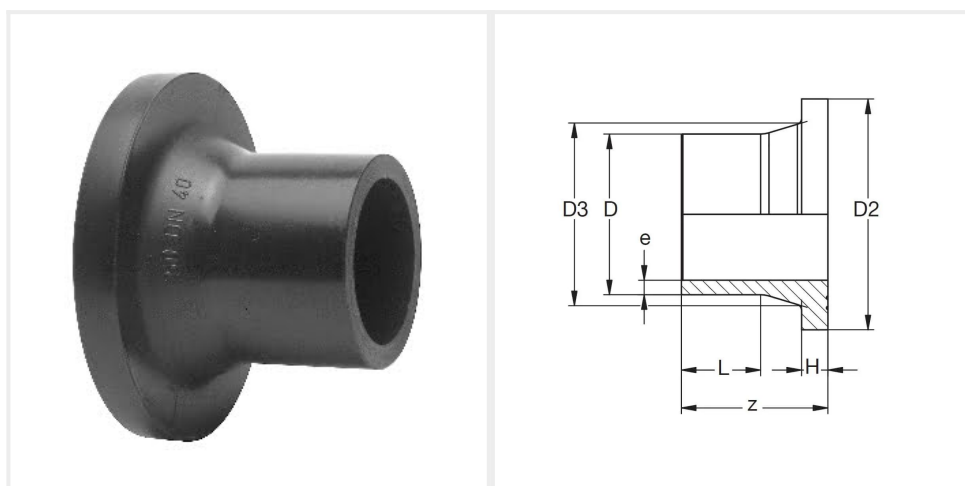

Cod: 25.80.01.101

- Material : PE100 virgin , culoare neagra
- Compatibilitate material : PE100 , PE100RC , PE80 , PEX
- Presiuni de lucru : PN10 Gaz , PN16 Apa (PE100 SDR11)
- Durata viata : minim 50 ani
- Respecta prevederile EN1555-3:2021 si EN12201-3:2021 respectiv ISO4437 si ISO4427
- Fabricate prin injectie in matrite
- Executie lunga pentru sudare cap cap si electrofuziune

Producator: Bänninger Kunststoff-Produkte GmbH - Germania

D (mm)	e (mm)	D2 (mm)	D3 (mm)	H (mm)	L (mm)	z (mm)	Greutate kg	buc/punga	buc/cutie	Presiune de lucru Gaz
25 A	2,3	58	33	9	18	35	0,031	10	170	PN10
32 A	3,0	68	40	10	18	40	0,043	10	140	PN10
40 A	3,7	78	50	11	18	40	0,064	10	150	PN10
50	4,6	88	61	12	23	60	0,095	10	90	PN10
63	5,8	102	75	14	31	75	0,16	2	12	PN10
75	6,8	122	89	16	34	80	0,25	2	36	PN10
90	8,2	138	105	17	43	90	0,35	2	24	PN10
110	10,0	158	125	18	47	100	0,54	2	12	PN10
125	11,4	158	132	25	55	110	0,66	2	10	PN10

## FISA TEHNICA

140	12,7	188	155	25	53	116	0,97	2	8	PN10
160	14,6	212	175	25	64	127	1,25	2	6	PN10
180	16,4	212	180	30	108	138	1,46	2	4	PN10
200	18,2	268	232	32	63	145	2,48	1	-	PN10
225	20,5	268	235	32	78	150	2,52	1	-	PN10
250	22,7	320	285	35	73	158	3,86	1	-	PN10
280	25,4	320	291	35	105	180	4,29	1	-	PN10
315	28,6	370	335	35	105	190	6,00	1	-	PN10
355	32,2	430	373	40	120	210	8,75	1	-	PN10
400	36,3	482	427	46	124	225	12,0	1	-	PN10
450	40,9	585	514	60	170	300	13,8	1	-	PN10
500	45,4	585	530	60	175	295	24,0	1	-	PN10
560	50,8	685	615	65	15	130	19,0	1	-	PN10
630	57,2	685	642	60	195	305	21,6	1	-	PN10
710	64,5	800	737	70	20	130	24,3	1	-	PN10
800	72,6	905	840	80	20	145	35,3	1	-	PN10
900	81,7	1005	944	85	20	180	52,0	1	-	PN10
1000	90,8	1110	1047	95	20	190	67,3	1	-	PN10